



Bobcat[®]

One Tough Animal.

DIESEL & LPG FORKLIFTS

NXP Series, Pneumatic, 2.0 to 3.5 ton capacity

🌐 Europe



INTRODUCTION

ONE TOUGH ANIMAL



BOBCAT'S HISTORY

In 1958, Melroe Manufacturing Company introduced a compact front-end loader that evolved quickly into the M400, the world's first true skid steer loader. The company soon adopted what became the world-famous 'Bobcat' brand – and its success paved the way for the global compact equipment industry we know today.

YEARS OF EXPERIENCE

In 2021, Bobcat expanded its portfolio by acquiring Doosan Industrial Vehicle. This specialist in material handling equipment constructed its first forklift in 1968 and went on to establish a global presence with 400 dealers in 93 countries.



BOBCAT TODAY

Bobcat is expanding its portfolio with the addition of forklifts and reach trucks for the material handling industry. Offering a comprehensive line-up that will meet all your intra-logistics needs. Bobcat forklifts and reach trucks are produced in our factory in Korea, while our premium quality warehouse equipment is made in Germany.



OUR MISSION

We empower operators to accomplish more, while working in the toughest conditions and tightest situations. When our customers have the will, we provide the way.

TOUGH, AGILE & SAFE

▶ UNMATCHED VALUE

The NXP Series combines entry-level accessibility with incredible power, durability, and operator comfort, promising outstanding value for your investment.



▶ **TOP PERFORMANCE, ALL DAY LONG**
Our powerful, fuel-efficient engines promise high-performance, all day long.
P. 6-7



▶ **CONFIDENCE IN COMFORT**
Easily navigate longer shifts with confidence thanks to an intuitive instrument panel, adjustable seat, small steering wheel, and spacious cab.



▶ **OUTSTANDING SAFETY**
With safety features like a mast lowering interlock, vibrant LED lights, and a reliable parking brake, operators can enjoy an even safer ride.
P. 10-11



▶ **BUILT TO LAST**
Built for durability, the NXP Series delivers reliability through features like optimized airflow, engine protection, robust mast design, reduced vibrations, and anti-dust measures. Enjoy the power of Bobcat for years to come.
P. 12-13

OUTSTANDING PRODUCTIVITY



▶ REACH HIGHER, ACHIEVE MORE

Our improved gear pump and mast regulator valve takes your truck to new heights, significantly increasing efficiency and productivity, especially in high-speed operations.



▶ LIFT BIGGER

Get more stability with our new auxiliary weight. This feature lowers the truck's center of gravity, allowing it to lift bigger and stronger in heavy-duty applications.



▶ NAVIGATE IMPOSSIBLE SPACES

Enjoy working in places where others cannot! Thanks to a small turning radius, you can maneuver in and out of the tightest spots with ease.



▶ ELEVATED PERFORMANCE

The combination of a robust engine, advanced transaxle, and innovative frame structure has optimized gradeability, allowing operators of the NXP Series to confidently scale steep slopes of up to 25% grade.

COMFORT & CONTROLS



▶ OPTIMIZED COMFORT & CONVENIENCE

Optimized for operator comfort and convenience, our cab design ensures efficient use of space, and a comfortable driving experience. Enjoy the benefits of a compact steering wheel, accompanied by an adjustable steering column and suspension seat.

▶ MORE LEG ROOM

With more knee clearance and a relocated tilt cylinder, our trucks offer more leg space for enhanced comfort.



▶ EFFORTLESS CONTROL

A compact steering wheel with a knob makes it easy to maneuver, control, and operate.

▶ SIMPLIFIED OPERATION

The headlamp switches are seamlessly integrated for effortless operation.

▶ EASY ENTRY



Our trucks are designed with operator comfort in mind with low step height, an easy entry bar, and a step plate enhanced with anti-slip tread.

▶ ENHANCED COMFORT



For even more comfort, we've relocated the steering column to the left for a more natural posture, while the instrument panel has been shifted to the right for improved visibility.

▶ SEE MORE, WORK BETTER



By lowering the cowl height (-40 mm) and tweaking the counterweight design, our NXP Series offers improved front and rear end visibility for safer driving conditions.



SAFETY IN EVERY MOVE

▶ SAFETY AT EVERY TURN

Operate the truck with complete confidence thanks to the remarkable visibility through an expanded mast window, strategically repositioned hydraulic hoses, and a reduced cowl height. Safeguard operations with features like a mast lowering interlock, vibrant LED lights, and a reliable parking brake, while operators enjoy an even safer ride with optional blue safety lights, zone lights, and a rear-view camera.

▶ OPERATOR SENSING SYSTEM (OSS)

The truck's travel and mast lifting functions stop when the operator leaves the seat so the forklift won't perform any unintended movements.



▶ A MORE SECURE WORKPLACE

When the operator leaves the truck unattended, the hydraulic locking system prevents unintentional lowering and tilting of the mast. This keeps the truck, load, and job site safe.



▶ PEDESTRIAN ALERTS

The blue safety light projects onto the floor around the truck, alerting pedestrians to the approaching vehicle.



▶ SAFETY ZONES

The vehicle projects red light-zone onto the ground, marking a safe area for pedestrians in close proximity to the vehicle.



▶ BACKUP ALARM

While traveling in reverse, the backup alarm sounds to warn people in the vicinity of the approaching truck, making the workplace safer for everyone.



▶ PARKING BRAKE ALERT

Prioritize operator safety and safeguard against accidental movement with our parking brake warning system.

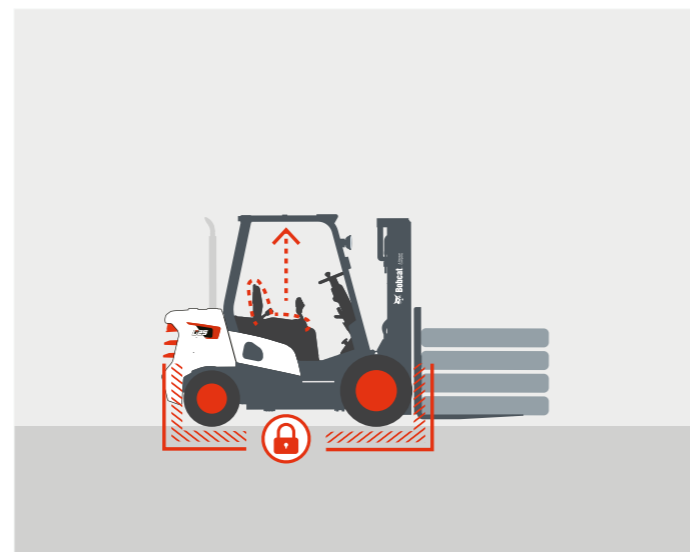

▶ PANORAMIC VIEW

Providing greater visibility of the rear working area, the large panoramic mirror improves safety while adding to overall productivity.



▶ ILLUMINATE YOUR WORKPLACE

The LED lights illuminate even the darkest corners of your workplace, keeping you safe and aware of your surroundings.



BUILT TO LAST

▶ NO JOB TOO TOUGH

Made for robust performance in heavy-duty and dusty environments, this truck offers anti-dust design, pre-cleaner, and double filter. It also boasts features like a protective belly plate, vented side panels, engine guard, and heavy-duty cooling for optimal functionality.

A wide hood opening with locking cylinders and a tool-less removable side panel for easy access

The reinforced ribs (J-channel) of the mast beam improve mast stiffness and lateral stability

Withstand the harshest conditions with the optional vented side panels, belly plate, pre-cleaner, and radiator screen.

Outstanding stability and reduced vibrations thanks to the newly redesigned auxiliary weight **P. 11**

Centralized electronic components for easier maintenance and reduced downtime

Adjusted muffler position for better airflow and increased cooling capacity

THERE'S NO TIME FOR DOWNTIME. STAND UP TO EVERY TASK THAT COMES YOUR WAY, DAY AFTER DAY.

2 YEAR WARRANTY

▶ WARRANTY

Bobcat develops every machine to the highest standards of quality and durability. That's why our standard warranty provides 24 months or 2 000 operating hours (whichever occurs first) of coverage.



▶ PROTECTION PLUS EXTENDED WARRANTY

Enjoy total peace of mind with Protection Plus extended warranty. Providing the same level of protection as the standard warranty, Protection Plus also reflects different customer needs and expectations by offering a choice of durations and annual operating hours.

▶ EXTENSIVE DEALER NETWORK

You can rely on our network of dealers and service partners who are always ready to help you.

▶ BOBCAT GENUINE PARTS

Quality components delivered to our dealers guarantee that all of our equipment is built to last, withstand the toughest conditions and provide reliable performance.

STANDARD EQUIPMENT & OPTIONS

STANDARD EQUIPMENT & OPTIONS		
	DIESEL TRUCKS NXP	LPG TRUCKS NXP
SAFETY & STABILITY		
Operating Sensing System (OSS)	✓	✓
Back-up alarm – inside	✓	✓
Control valve with hydraulic locking	✓	✓
Rear safety light(s)	•	•
Rear grab handle with horn switch	•	•
Static ground strap	•	•
Strobe light	•	•
Autoshift controller	•	•
Ground speed control	–	•
Spark arrestor	–	•
Red or blue fence (zone) lights	•	•
PRODUCTIVITY		
Auxiliary weight	✓	✓
Power shoe brakes	✓	✓
High-powered, fuel-efficient engine	✓	✓
Quick Disconnect Hose Couplings	✓	✓
RELIABILITY		
Mast with JJ beam	✓	✓
Anti dust overhead guard	✓	✓
Dual element air cleaner	✓	✓
Increased fan ratio	✓	✓
Bottom frame protection	✓	✓
Horizontal inside exhaust muffler	✓	✓
Pre-cleaner	•	•

STANDARD EQUIPMENT & OPTIONS		
	DIESEL TRUCKS NXP	LPG TRUCKS NXP
SERVICEABILITY		
Toolless side panel	✓	✓
Toolless floor plate	✓	✓
Hood locking cylinder	✓	✓
Junction box	✓	–
Separate brake oil reservoir with indicator	✓	✓
Tool kit	•	•
OPERATOR COMFORT (ERGONOMICS)		
Clear front/rear mast visibility	✓	✓
LED combination lights	✓	✓
Entry grab bar	✓	✓
Anti-slip step plate	✓	✓
Panoramic mirror	✓	✓
Integrated lamp switch	✓	✓
Compact steering wheel with steering knob	✓	✓
Clip board	✓	✓
Modular cab – Type A,B,C	•	•
Full cab (with heater & air conditioner)	•	•
Cup holder	•	•
USB port	•	•
Fuel cap with key	•	–
Operator fan	•	•

*This list is based on factory data. Standard or optional can vary for specific countries.
 • = option ✓ = standard – = not available



Compact steering wheel with steering knob



Anti-slip step plate



LED combination lights



Auxiliary weight



Quick disconnect hose couplings



Clipboard

MAIN SPECIFICATIONS – DIESEL

TECHNICAL DATA ACCORDING TO VDI 2198

CHARACTERISTICS		D20NX PLUS	D25NX PLUS	D30NX PLUS	D33NX PLUS	D35NX PLUS
Drive		Diesel				
Operator type		seated				
Load capacity (kg)	Q	2 000	2 500	3 000	3 300	3 500
Load center (mm)	c	500				
Load distance: center of drive axle to fork (mm)	x	472			477	
Wheelbase (mm)	y	1 700				
TIRES						
Tread, front (mm)	b11	1 060				
Tread, rear (mm)	b12	980				
DIMENSIONS						
Tilt of mast / fork carriage forward / backward (°)	α / β	6 / 10				
Height, mast lowered (mm)	h1	2 005 – 3 150				
Free lift (mm)	h2	150 – 1 940				
Lift (mm)	h3	3 000 – 7 060				
Height, mast extended (mm)	h4	3 824 – 8 298			3 829 – 8 303	
Height of overhead guard (mm)	h6	2 160				
Height of seat (mm)	h7	1 185				
Overall length (mm)	l1	3 610	3 660	3 715	3 780	3 800
Length to forkface (mm)	l2	2 560	2 610	2 665	2 730	2 750
Overall width (mm)	b1 / b2	1 290				
Fork dimensions (mm)	s / e / l	45 × 100 × 1 050		45 × 122 × 1 050		50 × 125 × 1 050
Fork carriage ISO 2328, class		II			III	
Fork carriage width (mm)	b3	1 042				
Ground clearance, loaded, below mast (mm)	m1	132				
Ground clearance, center of wheelbase (mm)	m2	135				
Aisle width for pallets 1 000 × 1 200 crossways (mm)	Ast	3 952	4 002	4 087	4 137	4 157
Aisle width for pallets 800 × 1 200 lengthways (mm)	Ast	4 152	4 202	4 287	4 337	4 357
External turning radius (mm)	Wa	2 280	2 330	2 415	2 460	2 480
Internal turning radius (mm)	b13	735				
PERFORMANCE DATA						
Travel speed, loaded / unloaded (km / h)		18.5 / 19.5				
Lift speed, loaded / unloaded (mm / s)		520 / 550			420 / 450	
Lowering speed, loaded / unloaded (mm / s)		420 / 550			470 / 500	
Drawbar pull, loaded / unloaded (@ 1.6 km / h) (kg)		1 805 / 1 764	1 785 / 1 754	1 764 / 1 734	1 754 / 1 713	1 744 / 1 693
Max. drawbar pull, loaded / unloaded (kg)		2 060 / 1 999	2 039 / 1 988	2 019 / 1 968	1 988 / 1 937	
Gradeability, loaded / unloaded (@ 1.6 km / h) (%)		30 / 55	28 / 50	23 / 42	22 / 40	
Max. gradeability, loaded / unloaded (%)		38 / 62	30 / 58	28 / 50	25 / 46	24 / 44
Service brake		Hydraulic				
COMBUSTION ENGINE						
Engine manufacturer / type		Kubota / V2403-CR-TE5B				
Engine power according to DIN ISO1585 (kW)		42.6				
Rated speed (min ⁻¹)		2 400				
Torque at 1 / min (N•m)		195.6 @ 1 500				
Cycle / number of cylinders / displacement (- / cm ³)		4 / 4 / 2 434				
Battery voltage / normal capacity (V / Ah)		12 / 90				

Specification values quoted in this specification sheet have been rounded. Performance may vary depending on operating conditions. Products and specifications are subject to improvement and change without prior notice. (1) Mast dimensions with load backrest refer to a range from the lowest to highest available mast.

Note: Load capacities are based on the standard chassis without side shifter.



SPECIFICATIONS

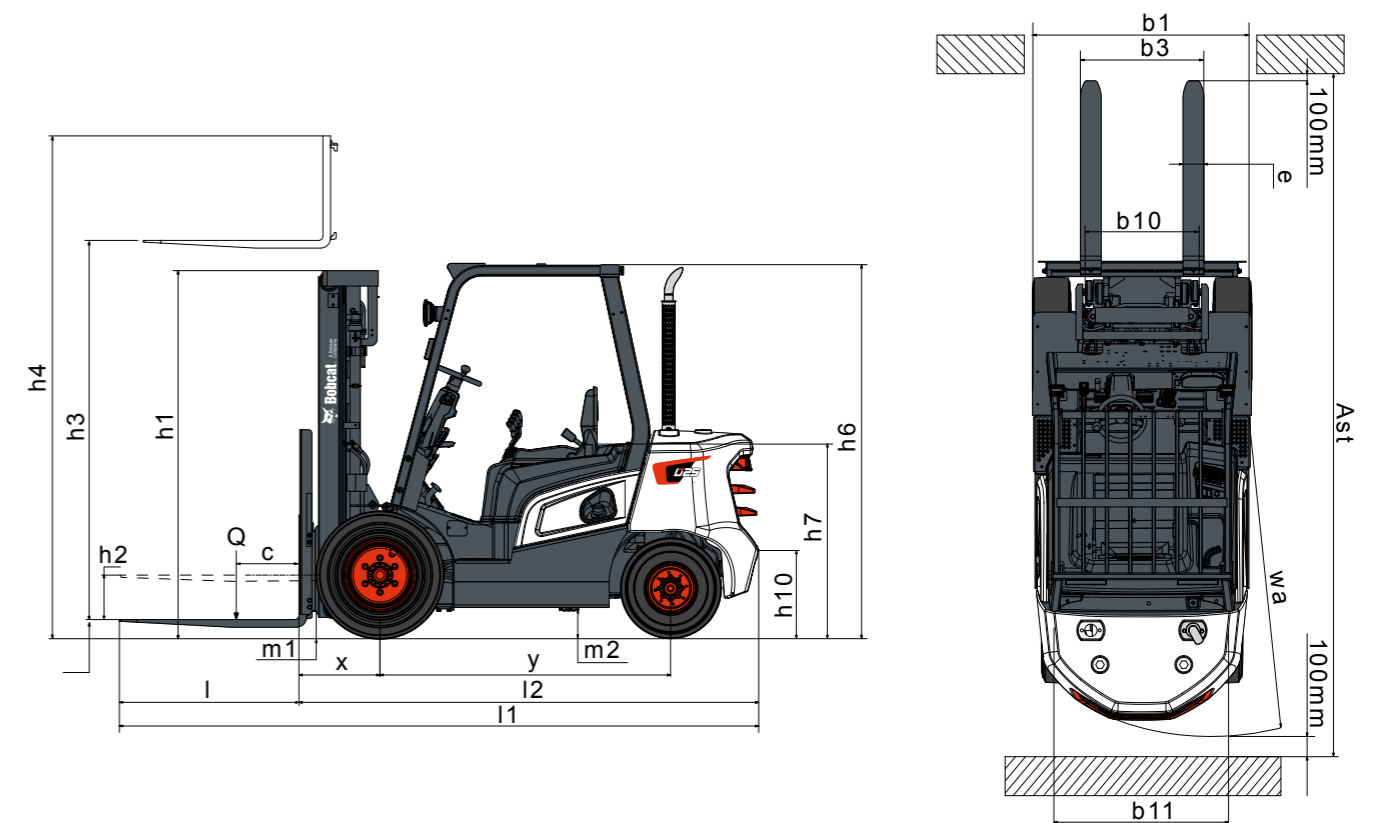

MAIN SPECIFICATIONS LPG

TECHNICAL DATA ACCORDING TO VDI 2198

CHARACTERISTICS		G25NX PLUS	G30NX PLUS	G33NX PLUS	G35NX PLUS
Drive		LPG			
Operator type		seated			
Load capacity (kg)	Q	2 500	3 000	3 300	3 500
Load center (mm)	c	500			
Load distance: center of drive axle to fork (mm)	x	472	477		
Wheelbase (mm)	y	1 700			
TIRES					
Tread front (mm)	b11	1 060			
Tread rear (mm)	b12	980			
DIMENSIONS					
Tilt of mast / fork carriage forward / backward (°)	α / β	6 / 10			
Height mast lowered (mm)	h1	2 005 – 3 150			
Free lift (mm)	h2	150 – 1 940			
Lift (mm)	h3	3 000 – 7 060			
Height mast extended (mm)	h4	3 824 – 8 298			3 829 – 8 303
Height of overhead guard (mm)	h6	2 160			
Height of seat (mm)	h7	1 185			
Overall length (mm)	l1	3 660	3 715	3 780	3 800
Length to forkface (mm)	l2	2 610	2 665	2 730	2 750
Overall width (mm)	b1 / b2	1 290			
Fork dimensions (mm)	s / e / l	45 × 100 × 1 050	45 × 122 × 1 050	50 × 125 × 1 050	
Fork carriage ISO 2328 class		II			III
Fork carriage width (mm)	b3	1 042			
Ground clearance loaded below mast (mm)	m1	132			
Ground clearance center of wheelbase (mm)	m2	135			
Aisle width for pallets 1 000 × 1 200 crossways (mm)	Ast	4 002	4 087	4 137	4 157
Aisle width for pallets 800 × 1 200 lengthways (mm)	Ast	4 202	4 287	4 337	4 357
External turning radius (mm)	Wa	2 330	2 415	2 460	2 480
Internal turning radius (mm)	b13	735			
PERFORMANCE DATA					
Travel speed loaded / unloaded (km / h)		20 / 21			
Lift speed loaded / unloaded (mm / s)		510 / 530			410 / 430
Lowering speed loaded / unloaded (mm / s)		420 / 550			470 / 500
Drawbar pull loaded / unloaded (@ 1.6 km / h) (kg)		1 754 / 1 716	1 723 / 1 703	1 713 / 1 693	1 703 / 1 693
Max. drawbar pull loaded / unloaded (kg)		1 968 / 1 907	1 948 / 1 897	1 937 / 1 886	1 927 / 1 886
Gradeability loaded / unloaded (@ 1.6 km / h) (%)		28 / 48	24 / 42	22 / 40	21 / 38
Max. gradeability loaded / unloaded (%)		32 / 55	27 / 48	25 / 45	24 / 43
Service brake		Hydraulic			
COMBUSTION ENGINE					
Engine manufacturer / type		HMC G424I			
Engine power according to DIN ISO1585 (kW)		45.4			
Rated speed (min ⁻¹)		2 600			
Torque at 1 / min (N•m)		179 @ 2 000			
Cycle / number of cylinders / displacement (- / cm ³)		4 / 4 / 2 359			
Battery voltage / normal capacity (V / Ah)		12 / 45			



SPECIFICATIONS

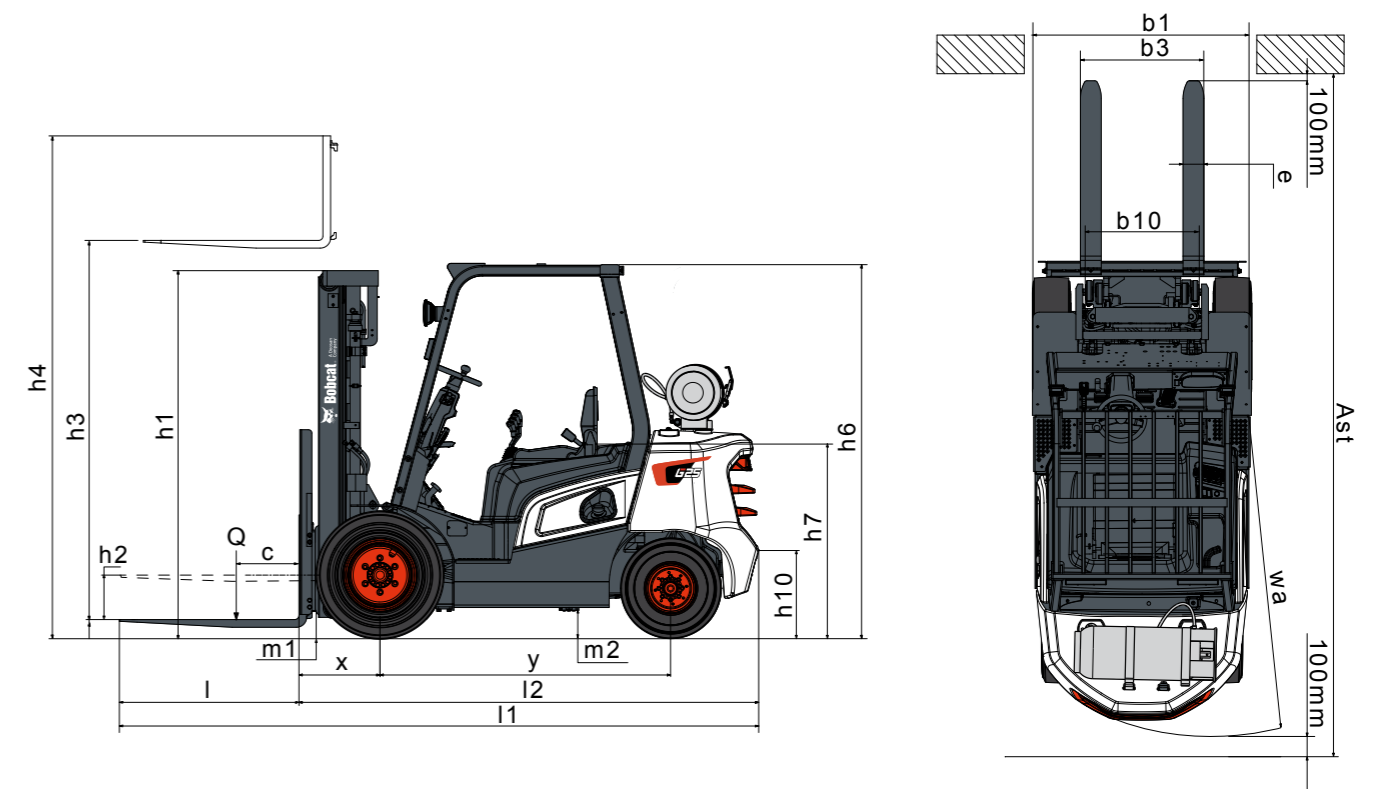

Specification values quoted in this specification sheet have been rounded. Performance may vary depending on operating conditions. Products and specifications are subject to improvement and change without prior notice. (1) Mast dimensions with load backrest refer to a range from the lowest to highest available mast.

Note: Load capacities are based on the standard chassis without side shifter.

FINANCING OPTIONS

24, 36, OR 48 MONTH FINANCING*

Take advantage of 24, 36 or 48 month financing programs starting from **0% interest** and improve your cashflow.

Ask your dealer for the financing offers available.

340 MACHINES / 46 PRODUCT FAMILIES / 1 TOUGH ANIMAL



**SKID-STEER
LOADERS**



**COMPACT TRACK
LOADERS**

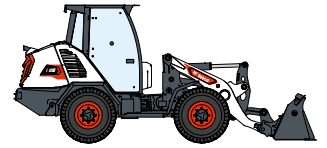

**COMPACT WHEEL
LOADERS**



FORKLIFTS

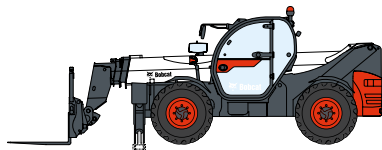

TELEHANDLERS

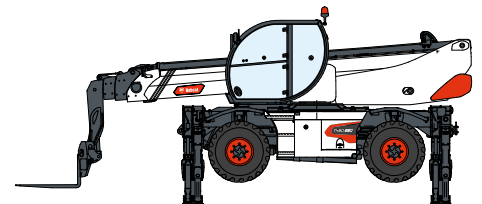

ROTARY TELEHANDLERS



**LIGHT COMPACTION
EQUIPMENT**



**COMPACT
EXCAVATORS**



**COMPACT
TRACTORS**



**SMALL ARTICULATED
LOADERS**



**MINI TRACK
LOADER**



MOWERS

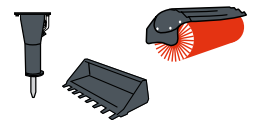

ATTACHMENTS

DOOSAN

Bobcat is a Doosan Company. Doosan is a global leader in construction equipment, power & water solutions, engines, and engineering proudly serving customers and communities for more than a century. | Bobcat and the Bobcat logo are registered trademarks of Bobcat Company in the United States and various other countries. ©2024 Bobcat Company. All Rights Reserved.

www.bobcat.com

©2024 BOBCAT B4502590-EN (02-24)



Bobcat®

*Financing options may vary by country and dealer. Always ask your dealer about currently available financing options. Terms and conditions may apply.

Doosan Bobcat EMEA, U Kodelky 1810, 263 12 Dobříš, Czech Republic